

LABBEASY

LABBEASY

Origami Boxes

Instructions for five different origami boxes

LABBEASY

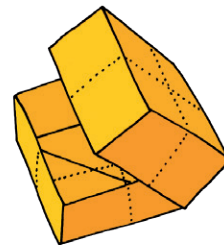
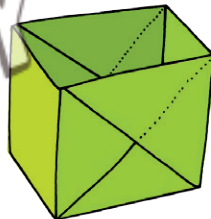
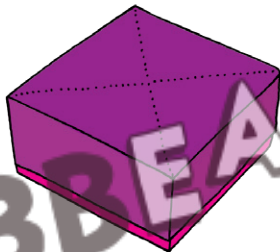
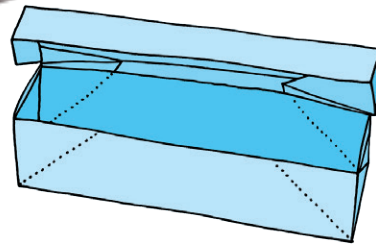
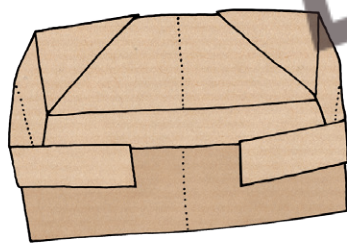

LABBEASY

LABBEASY

PDF 4123-EN

LABBEASY

LABBEASY

Origami Boxes

Instructions	Page 3
Odds and ends box	Pages 4 - 6
Dice box	Pages 7 - 10
Box with lid	Pages 11 - 13
Masu box	Pages 14 - 16
Pencil case	Pages 17 - 21
Patterned sheets, rectangular	Pages 22 - 26
Patterned sheets, square	Pages 27 - 31

PRINT SETTINGS

Please use Acrobat Reader to print and make sure that the settings 'Actual size' and 'Auto portrait/landscape' are selected.

SAVE PAPER & TONER

Only print out the pages you need.

COPYRIGHT & LICENCE

This material is protected by copyright. Labbé holds exclusive rights. © Labbé Publishing

This PDF file may only be used by the original purchaser and is intended for personal use and teaching. Distribution of the PDF file to school staff or to parents and students is not permitted. It is also not permitted to make it available on the internet or to place it on a school server. It is prohibited to use the PDF file, printouts of the PDF file, and objects created from it for commercial purposes. For more information, visit www.labbeasy.com

HOW TO DO IT

Origami Boxes

1

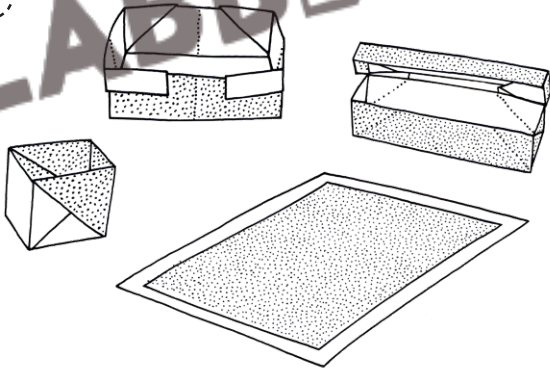

Choose the desired box instructions and print them if you wish. Then select a patterned sheet and print it out.

2

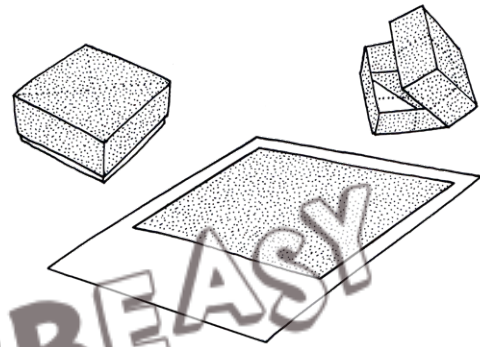

For boxes that require square paper, print out a square patterned sheet. For boxes that require rectangular paper, a rectangular patterned sheet is printed out.

3

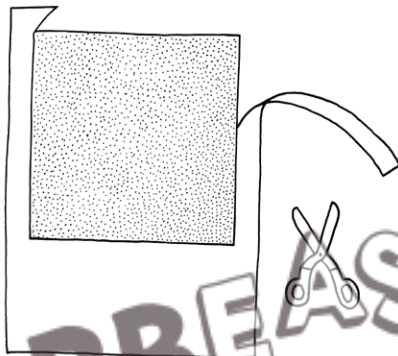

Cut out the patterned part of the sheet along the outside edges.

4

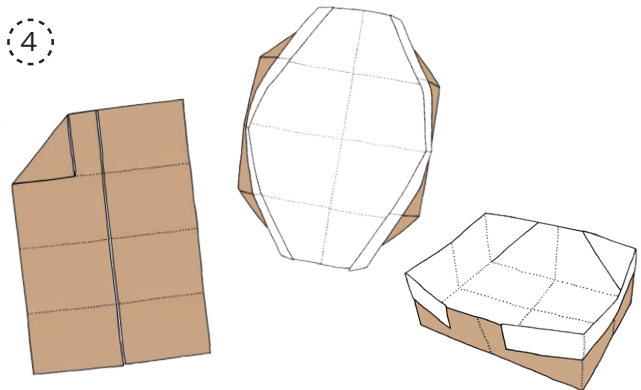

You can now start folding! In these instructions, we indicate the patterned side of the paper with color.

TIPS

1

The patterned sheets can also be printed on colored paper or colored in with pencils.

2

If you're a practiced origami master, you can use any other paper at the same size, such as wrapping paper, newspaper, etc.

3

As with all origami folding: The more accurate the folds, the better the result.

4

It's really important to score the edges (ideally with your fingernail). New edges should be scored again after each step.

HOW TO DO IT

Odds and Ends Box

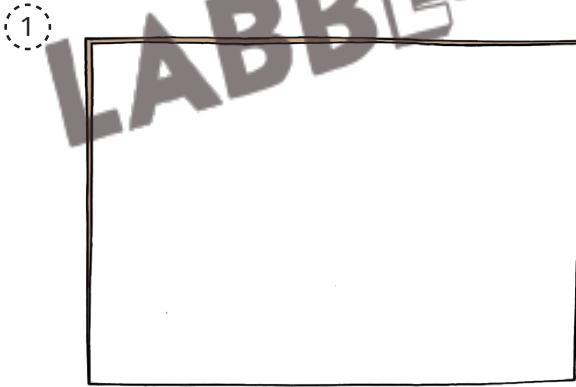
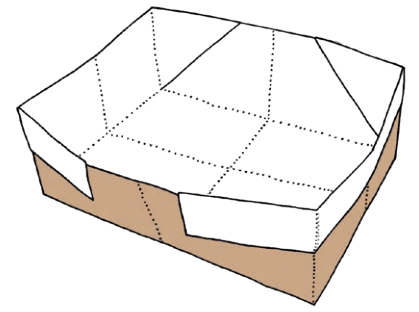

Fold a rectangular sheet in half.



Fold the sheet in half again.

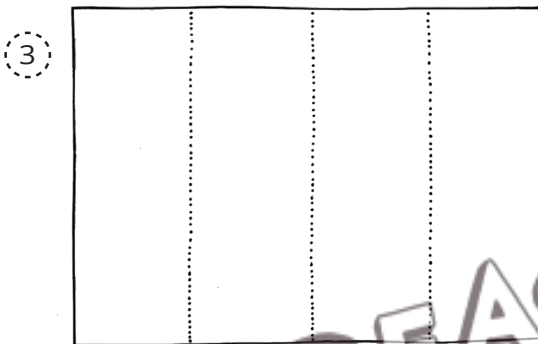

Completely unfold the sheet and turn it 90 °.

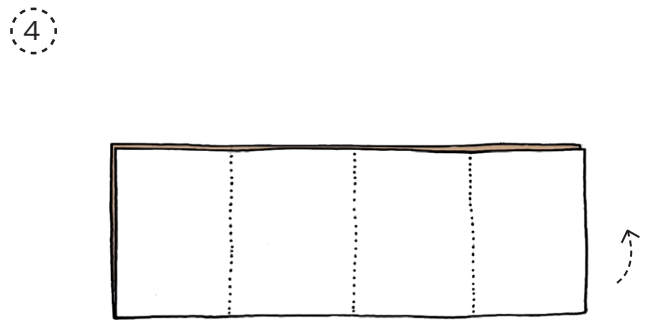

Fold the sheet in half again.

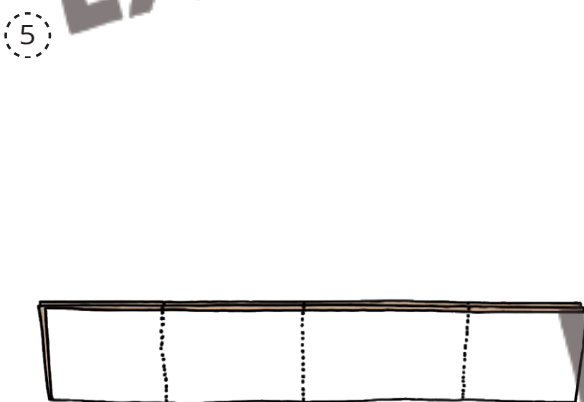

And fold the sheet in half once more.

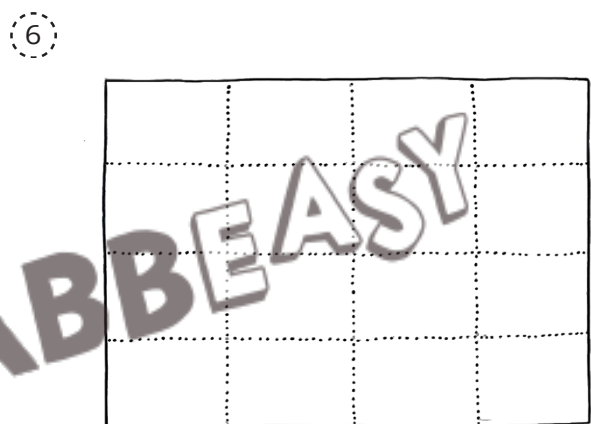

Unfold the sheet and smooth it flat with your hand.

7

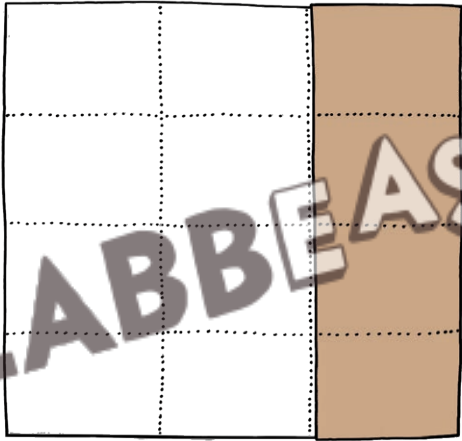

Fold the right-hand strip inwards.

8

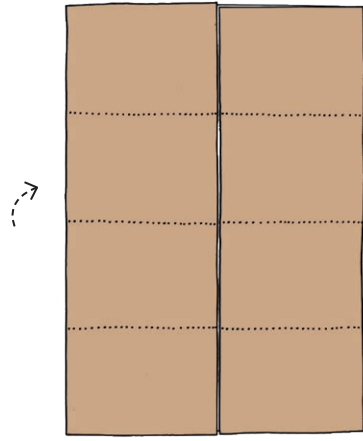

Fold the left-hand strip inwards.

9

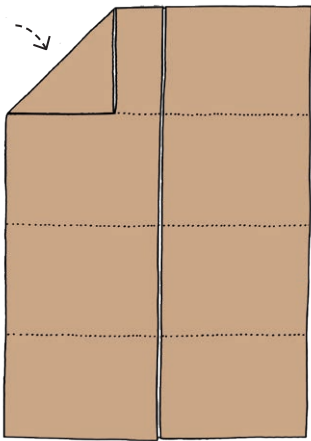

Fold down the top left corner to meet the upper fold line.

10

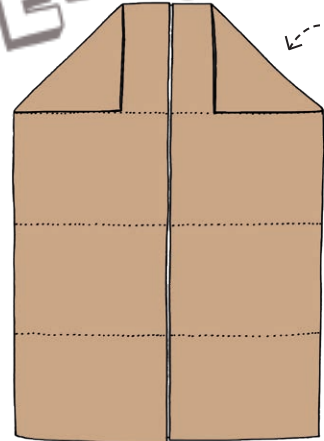

Fold down the top right corner to meet the upper fold line.

11

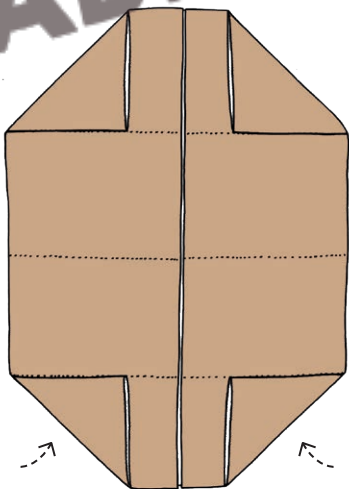

Fold both bottom corners in the same way.

12

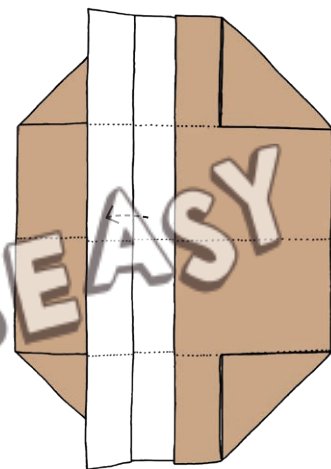

Fold the left inner edge outwards.