

LABBEASY

LABBEASY

Paper Planes

Folding instructions for making six different paper planes

LABBEASY

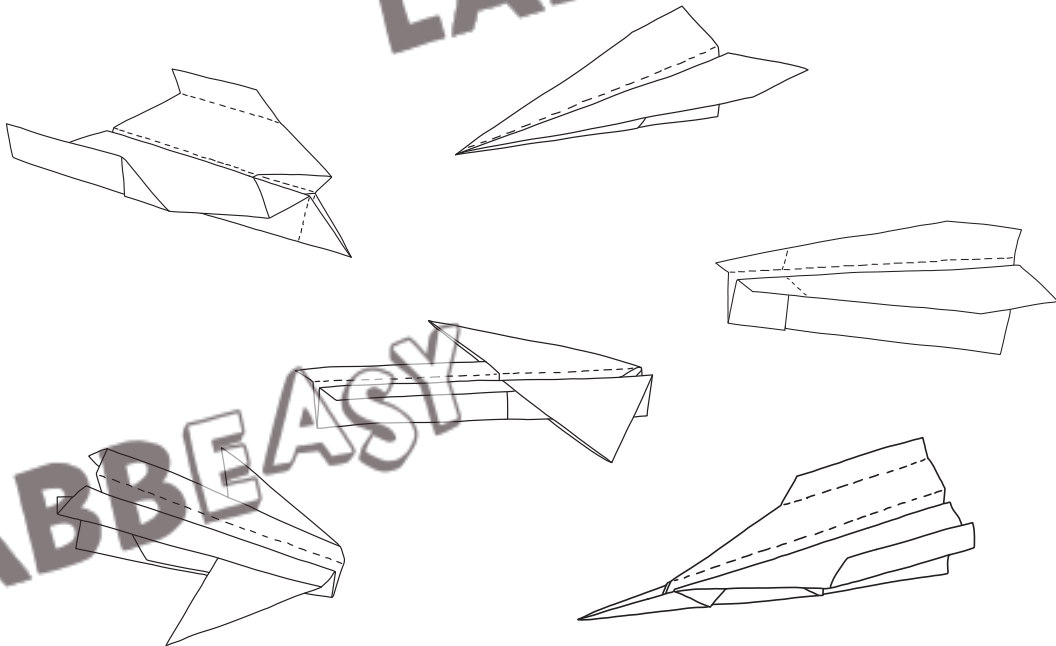

LABBEASY

LABBEASY

LABBEASY

LABBEASY

Paper Planes

Overview	Page 3
Dart	Pages 4 - 5
Hawk	Pages 6 - 9
Swift	Pages 10 - 13
Acrobat	Pages 14 - 17
Arrow	Pages 18 - 21
Sparrow	Pages 22 - 24

PRINT SETTINGS

Please use Acrobat Reader to print and make sure that the settings 'Actual size' and 'Auto portrait/landscape' are selected.

SAVE PAPER & TONER

Only print out the pages you need.

COPYRIGHT & LICENCE

This material is protected by copyright. Labbé holds exclusive rights. © Labbé Publishing

This PDF file may only be used by the original purchaser and is intended for personal use and teaching. Distribution of the PDF file to school staff or to parents and students is not permitted. It is also not permitted to make it available on the internet or to place it on a school server. It is prohibited to use the PDF file, printouts of the PDF file, and objects created from it for commercial purposes. For more information, visit www.labbeasy.com

OVERVIEW

Paper Planes

LABBEASY

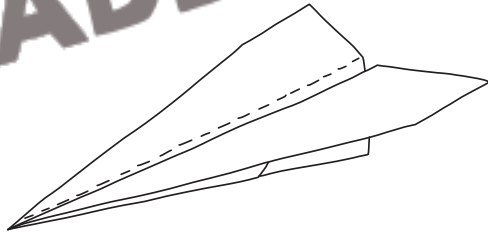

DART
Pages 4 - 5

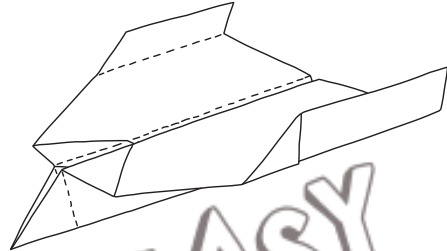

HAWK
Pages 6 - 9

LABBEASY

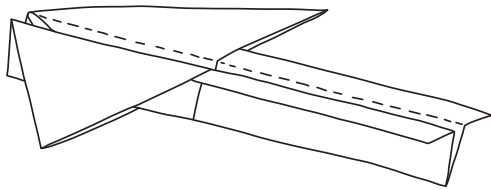

SWIFT
Pages 10 - 13

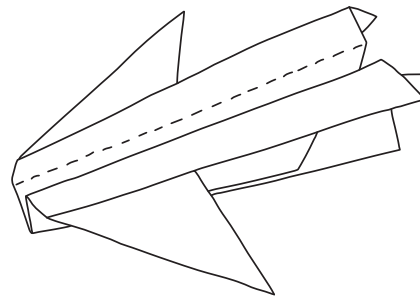

ACROBAT
Pages 14 - 17

LABBEASY

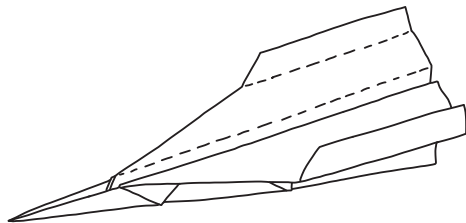

ARROW
Pages 18 - 21



SPARROW
Pages 22 - 24

LABBEASY

HOW TO DO IT

Dart

①



Fold the sheet in half lengthwise and then unfold it again.

②

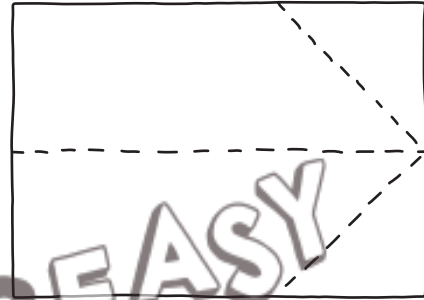

Fold the top right and bottom right corners to the center line.

③

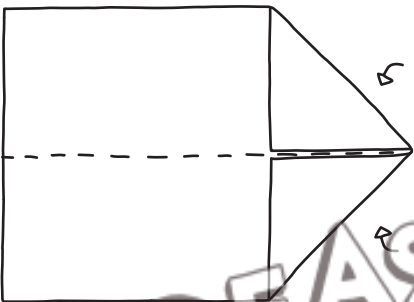

This will give you a point. Always score the folded edges with your fingernail.

④

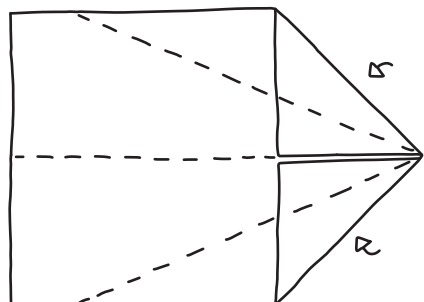

Fold the top right and and bottom right corners to the middle line once more.

⑤

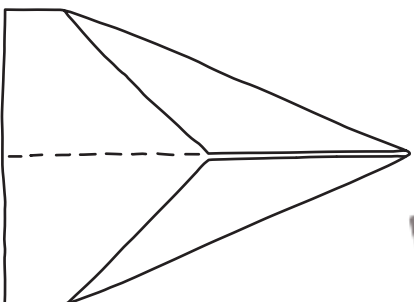

This will give you a long point.

⑥



Turn the plane over.

7

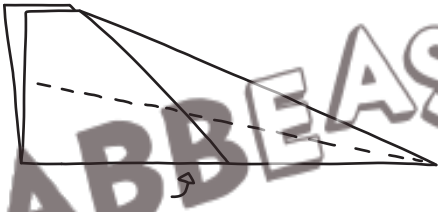

Fold the plane together in the middle.

8

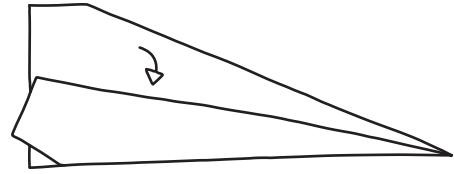

Carefully fold the wing that's on top down to meet the bottom edge.

9

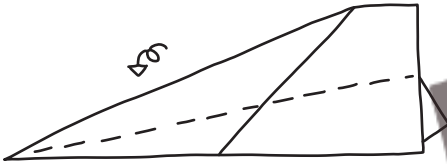

Turn the plane over again.

10



Fold down the second wing to meet the bottom edge just like you did with the other one.

11



Raise both wings until they're level.

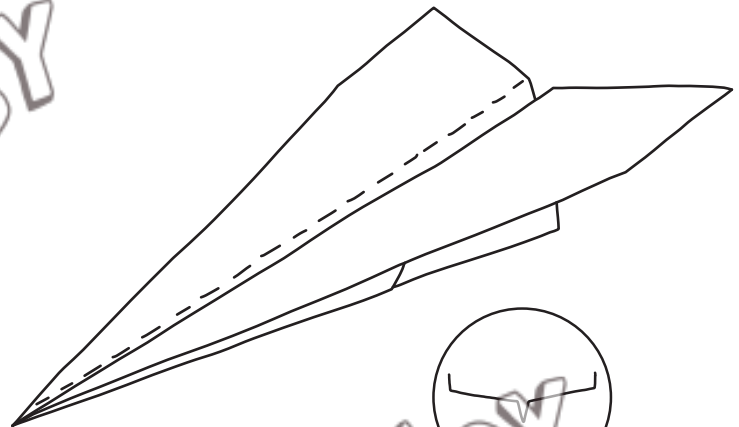

Front-on view